

# Stationary placing boom

## MXG 42-5

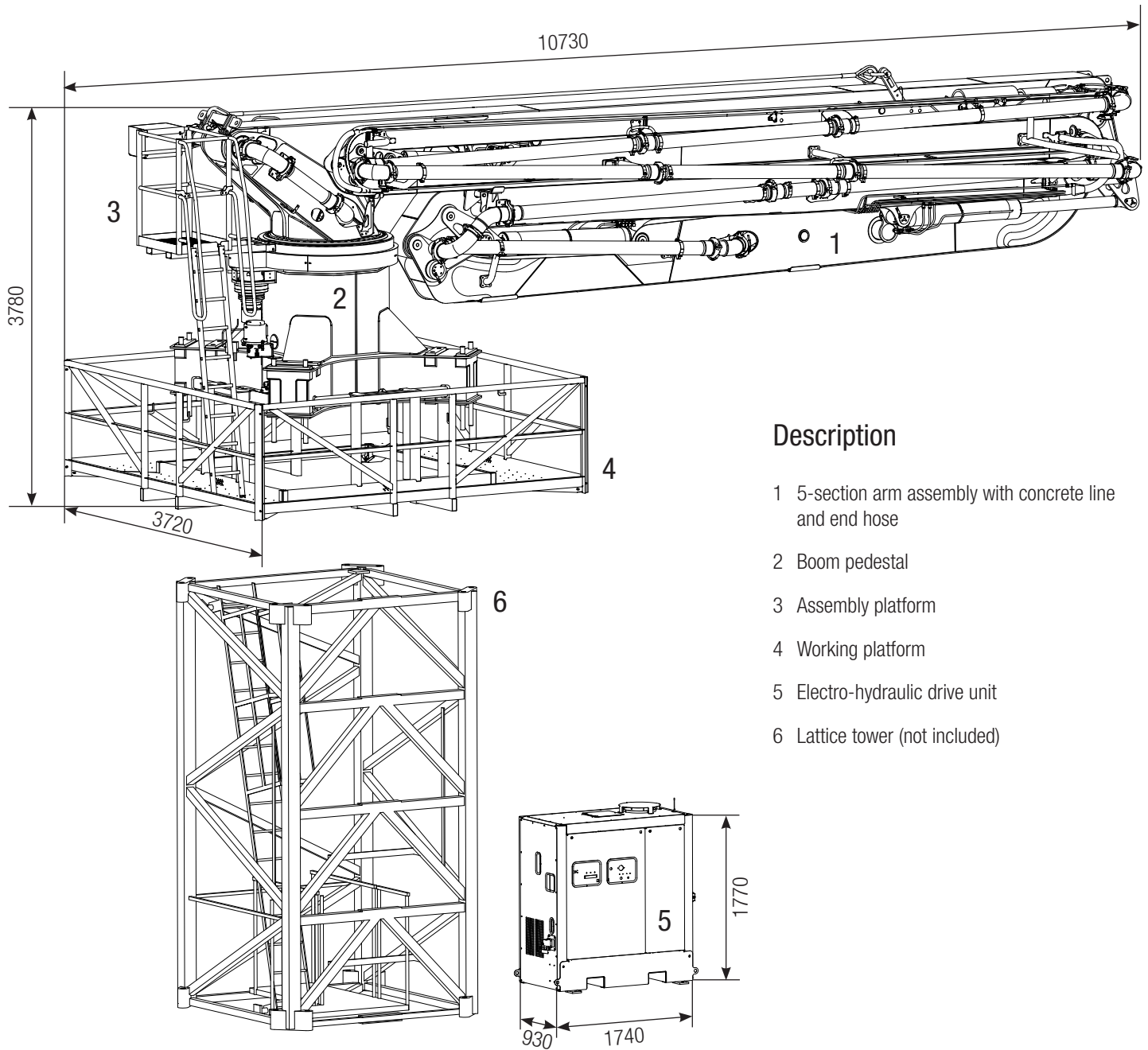

### Description

- 1 5-section arm assembly with concrete line and end hose
- 2 Boom pedestal
- 3 Assembly platform
- 4 Working platform
- 5 Electro-hydraulic drive unit
- 6 Lattice tower (not included)

Note: Standard version. Dimensions and weights depend on equipment. Subject to technical modifications and errors.

## Reach information diagram

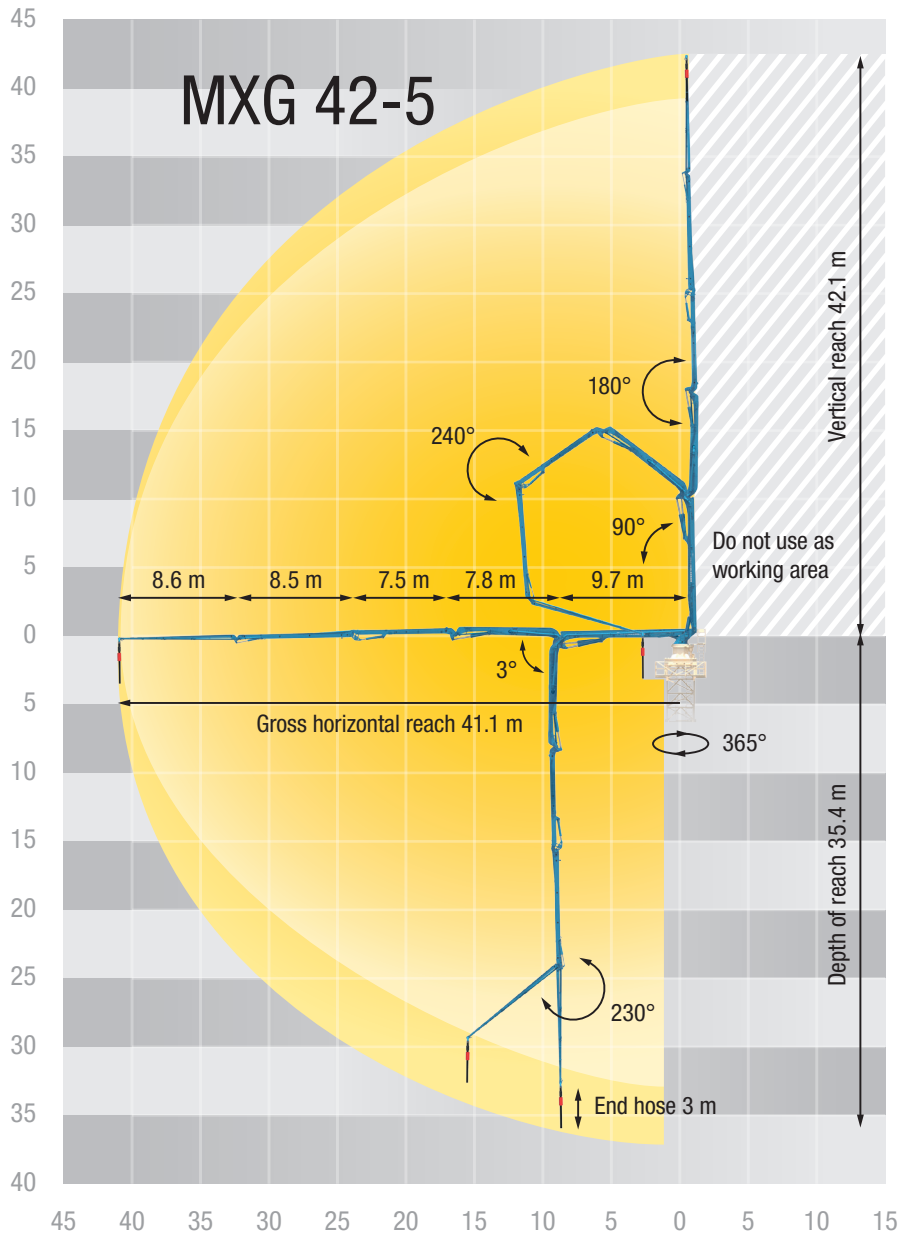

## Technical data

Stationary placing boom		MXG 42-5
Sections		5
Reach height	m	42.1
Horizontal reach	m	41.1
Reach depth max.	m	35.4
Delivery line		DN 125
End hose length	m	3
Slewing range	°	365
Weight (boom + pedestal + working platform)	t	13
Weight (hydraulic drive unit)	t	1.3

All data max. theor.

Dimensions can differ depending on configuration.

## Serial delivery scope

Arm assembly MXR 42-5
Boom pedestal MXG 42-5 for lattice tower
Central lubrication system
Delivery line DN 125
Assembly platform

Electric motor with soft start
Electro-hydraulic power pack
End hose 3.0 m DN 125 5.5"
Hose package 20 m (connection arm assembly to power pack)
Radio remote control

Operating manuals (1× paper, 1× CD-ROM), spare part list
Painting: arm assembly RAL 5012 light blue
Painting: base structure* RAL 1015 light ivory
Soft start
Working platform

See quotation for exact serial delivery scope.  
Comprehensive range of options available on request.

\* Boom pedestal, assembly platform, working platform