



**Putzmeister**



# Solids handling pumps HSP

For fine grain slurries with a high percentage of solids

# Solids pumps HSP

## Oil-hydraulic piston pump with seat valves

The seat valve pump is used for arduous applications. The HSP series is used with pastelike and highly viscous material with a low content of foreign bodies and small particle sizes.



Precise sealing of the valves means that extremely high pumping pressures can be achieved. The principle behind the design of the hydraulic and pumping pistons ensures maximum reliability and availability.

Two special features of the Putzmeister design are that not only is it a simple matter to replace the valves but the design also means a long service life for all wearing parts. Valves and valve seatings are made of highly wear-resistant steels and can be used at either end. This doubles their service life. Valves can be easily replaced without dismantling the delivery lines.

A pulsation-free conveyance can be achieved with the PCF system (Pressure Constant Flow, optional)

## Features and advantages

- For conveying fine-grained sludges or slurries
- Switch-over without shorting
- No backflow at high pressures
- With positive supply pressure no booster pump is required
- PCF system for an almost pulsation-free conveyance (optional)
- Output up to 385 m<sup>3</sup>/h
- Delivery pressure up to 150 bar

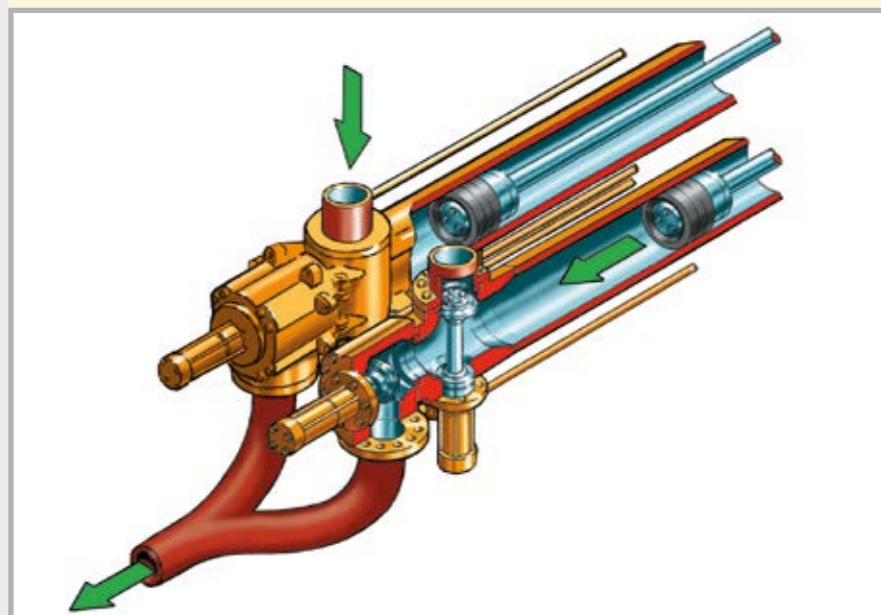

HSP pumps are mainly used where fine slurries laden with a high proportion of solids must be conveyed against high pressures:

- Mineral solids (tailings) with a dry solids content of up to 80 %
- Fluids containing slurry, e.g. pit water
- Thick pastes of electro filter ash with low water content
- Various chemical and organic solids
- Sewage sludge with a high proportion of solids (moist, compact)

Systems using HSP pumps can be found in many industries:

- Mining (de-watering of mines, backfilling, pumping of tailings)
- Sewage works (transport of sewage sludge)
- Power stations (transport of fly ash)
- Waste recycling (transport of oil sludge)



Sewage sludge



Fly ash



Tailings

# The piston pumps with hydraulically-operated seat valves

# Putzmeister Pulsation Dampening Systems

## The pump head

The principal feature of the HSP pump series is the hydraulically-controlled disc valves. The pumps are either Duplex, Duo or Single pumps with different pump heads.

The „C pump heads“ are designed as individual heads and can be folded open, making them easily accessible for the inspection and replacement of wearing parts.

The „B pump head“ has a horizontal pressure line outlet and two vertical intake ports, providing compact design on all machine sizes.

On versions with the „E pump head“, two lines supply the pump with the product to be delivered. The delivery outlet is perpendicular to the pump direction. A pipeline bend at

the outlet allows the delivery line to be routed in any direction. The delivery line is, therefore, kept free of tension and is easy to open in the event of repair work.

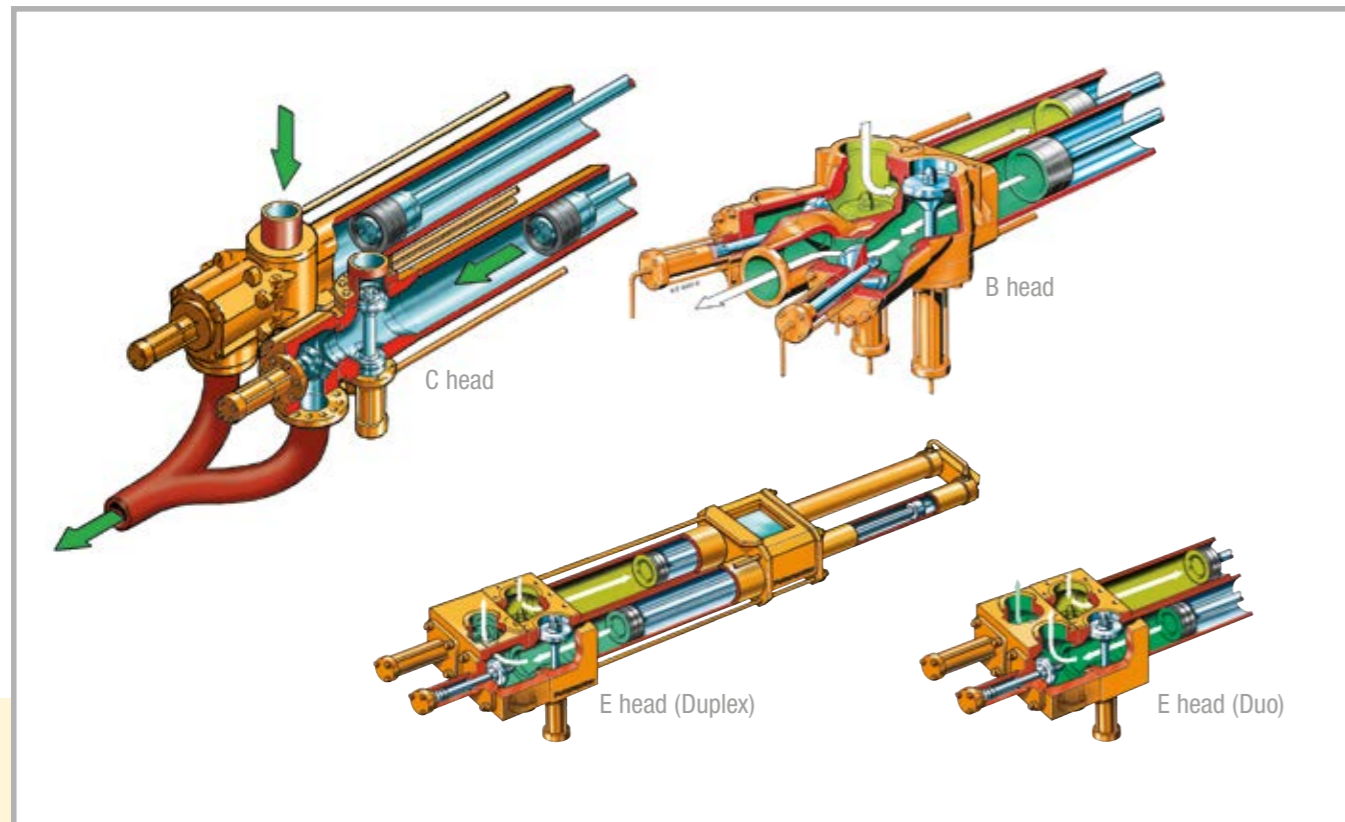

### Duplex HSP

In this standard version, two delivery pistons running opposed to one another supply a common delivery line. Interruptions to delivery when the delivery pistons switch over are only minimal (0.2 – 0.3 seconds). A damping vessel renders such interruptions even less significant.

### Duo HSP

Each cylinder pumps separately from its own intake line to its own delivery line. Without the need for complicated distribution systems, the conveyed product is pumped in equal quantities to two different areas.

## PCF – Putzmeister Constant Flow

The Putzmeister Constant Flow (PCF) System is the best pulsation dampening system for seat valve – or ball valve pumps as no additional mechanical components have to be installed within the delivery pipeline.

The only required Equipment is a Putzmeister Seat Valve (HSP) or Ball Valve (KOV) Piston Pump equipped with a PCF Hydraulic Power Pack.

## Advantages of the PCF system

- **Best Possible Dampening Device for Seat valve Pumps**
- **PCF is working in different pressure levels without any adjustment**
- **PCF has no membrane or other additional mechanical parts with a limited life time**
- **PCF can be used for different pumping material at the same installation, even for paste containing cement or other additives**
- **Easy cleaning and maintenance of the entire system as no additional mechanical parts have to be installed within the pipeline**
- **Can be used for hardening material (cemented paste)**
- **Reliable operation at 150 bar (2.175 psi) continuous pumping pressure can be realized with Putzmeister Seat Valve Piston Pumps (HSP)**

## Advantages of the VPD system

- **Economic system driven by compressed air used as a spring**
- **No wear parts (membrane) necessary**
- **No permanent loss of energy (the compressor is only needed if the output or the pressure are changing)**
- **Easy cleaning and maintenance**
- **Elimination of water hammers in the pipeline**
- **Working in different pressure levels without any manual adjustment**
- **Designed as a stand-alone unit and usually driven by a dedicated compressor**
- **Application for new installations as well as easy retrofit for all kind of existing pumps**



HSP 25100 HPS, PCF valves, Hydraulic Powerpack HA 400 + 400 E-SP



VPD system installed after a HSP piston pump for tailings handling

## VPD – Putzmeister Ventilated Pulsation Damper

The VPD System is mounted in the delivery pipeline after the pressure outlet of the pump and consists of the dampening unit itself an air distribution and air storage unit as well as a compressor unit.

During the pump stroke of the pump, the pre-compressed air in the dampers gets further compressed by the medium. Hence, the medium rises in the dampers. During the changeover of the seat valves or the S-tube, the compressed air

presses the medium downwards into the conveying pipe, whereby the pressure collapse is reduced. The amount of air needed is detected by a pressure sensor in the damping unit, calculated by the controller, generated from the compressor and provided from the storage unit.

Due to the design of the VPD it can be only used for non-hardening slurries and paste. Cemented paste must not be pumped through this system.

# Accessories for custom design and equipment of your system

# HSP Technical data

## Delivery lines

Delivery lines in industry must especially be safe over a long period of operation (24/7). The pressure resistance with pulsating load is one particular criteria when designing the delivery line. These can be designed in DIN, SK and ZX with different flange and coupling systems. The Putzmeister SK and ZX systems have proved themselves worthy for abrasive and non-abrasive materials. They have a clamp coupling for easy installation and removal.

ZX delivery lines are used in sewage treatment works, in waste recycling, in coal-fired power plants, waters desludging, in mining and other numerous special applications. Depending on the application, the design, material and the surface treatment can be modified in order to be ideally adapted to the pump and material to be conveyed.



## Ball, gate or diversion valves

Delivery line components must be designed regarding the dynamic loads and characteristics of the media. Ball valves for example are therefore equipped with stronger shaft shanks and flush connections.

Gate and diversion valves are essential when multiple delivery lines have to be installed. Thus, the material located in the pipeline after the pump can be diverted through a gate valve to other routes such as a thermal dryer or intermediate storage.

Gate valves are hydraulically operated. For a faster switch, it is suggested to use a power pack of at least 7.5 kW. The valve housing is sealed with hardened sealing rings, that are pressed against the moving blade of the valve.

## A wide range of application specific components and functions are available for extreme operation, e.g.

- Feed auger
- Receiver container with or without agitator
- Intake piping with gate valve
- Vibration damper for the delivery system
- Gate and distribution valves
- Boundary layer lubricant injection station
- Scraper pig gates for delivery line cleaning



Type	Output*	Permanent delivery pressure**	Delivery cylinder Ø	Delivery cylinder length	Cylinder volume per stroke	Type HSP head	Length (L)	Width (W)	Height (H)	Weight approx.
<b>HSP 1040</b>	25 m³/h 110 gpm	64 bar 930 psi	150 mm 5,91 in	1000 mm 39,37 in	16,30 l 4,23 gal	E	4100 mm 161,42 in	1120 mm 44,09 in	950 mm 37,41 in	2500 kg 5512 lb
<b>HSP 1040 HP</b>	25 m³/h 110 gpm	100 bar 1450 psi	150 mm 5,91 in	1000 mm 39,37 in	16,30 l 4,23 gal	E	4100 mm 161,42 in	1120 mm 44,09 in	950 mm 37,41 in	2500 kg 5512 lb
<b>HSP 1070</b>	55 m³/h 240 gpm	64 bar 930 psi	230 mm 9,06 in	1000 mm 39,37 in	34,90 l 8,98 gal	E	4100 mm 161,42 in	1120 mm 44,09 in	950 mm 37,41 in	3000 kg 6614 lb
<b>HSP 1070 HP</b>	55 m³/h 240 gpm	100 bar 1450 psi	230 mm 9,06 in	1000 mm 39,37 in	34,90 l 8,98 gal	E	4100 mm 161,42 in	1120 mm 44,09 in	950 mm 37,41 in	3200 kg 7055 lb
<b>HSP 2180</b>	95 m³/h 420 gpm	64 bar 930 psi	280 mm 11,02 in	2100 mm 82,68 in	113,30 l 29,85 gal	B	5750 mm 226,38 in	1600 mm 62,99 in	1310 mm 51,57 in	5050 kg 11133 lb
<b>HSP 2180 HP</b>	95 m³/h 420 gpm	100 bar 1450 psi	280 mm 11,02 in	2100 mm 82,68 in	113,30 l 29,85 gal	B	5750 mm 226,38 in	1600 mm 62,99 in	1310 mm 51,57 in	5200 kg 11464 lb
<b>HSP 2180 HPS</b>	95 m³/h 420 gpm	150 bar 2175 psi	280 mm 11,02 in	2100 mm 82,68 in	120,50 l 31,70 gal	C	7155 mm 281,69 in	2100 mm 82,68 in	1335 mm 52,56 in	9200 kg 20282 lb
<b>HSP 25100</b>	160 m³/h 705 gpm	64 bar 930 psi	360 mm 14,17 in	2500 mm 98,43 in	216,40 l 57,06 gal	B	8100 mm 318,89 in	1420 mm 55,91 in	1410 mm 55,51 in	8900 kg 19621 lb
<b>HSP 25100 HP</b>	160 m³/h 705 gpm	100 bar 1450 psi	360 mm 14,17 in	2500 mm 98,43 in	216,40 l 57,06 gal	B	8100 mm 318,89 in	1420 mm 55,91 in	1410 mm 55,51 in	9200 kg 20282 lb
<b>HSP 25100 HPS</b>	160 m³/h 705 gpm	150 bar 2175 psi	360 mm 14,17 in	2500 mm 98,43 in	229,00 l 60,49 gal	C	8300 mm 326,77 in	2100 mm 82,68 in	1880 mm 74,02 in	15000 kg 33069 lb
<b>HSP 25150</b>	250 m³/h 1100 gpm	64 bar 930 psi	450 mm 17,72 in	2500 mm 98,43 in	338,10 l 89,33 gal	C	8920 mm 351,18 in	2065 mm 81,29 in	2340 mm 92,13 in	13500 kg 29762 lb
<b>HSP 25150 HP</b>	250 m³/h 1100 gpm	120 bar 1740 psi	450 mm 17,72 in	2500 mm 98,43 in	357,80 l 94,28 gal	C	8920 mm 351,18 in	2065 mm 81,29 in	2340 mm 92,13 in	15750 kg 34723 lb
<b>HSP 25150 HPS</b>	250 m³/h 1100 gpm	150 bar 2175 psi	450 mm 17,72 in	2500 mm 98,43 in	373,70 l 98,73 gal	C	8920 mm 351,18 in	2065 mm 81,29 in	2340 mm 92,13 in	19500 kg 42990 lb
<b>HSP 25200</b>	385 m³/h 1695 gpm	64 bar 930 psi	560 mm 22,05 in	2500 mm 98,43 in	554,20 l 146,42 gal	D	8510 mm 335,04 in	2300 mm 90,55 in	2055 mm 80,91 in	17000 kg 37478 lb
<b>HSP 25200 HP</b>	385 m³/h 1695 gpm	100 bar 1450 psi	560 mm 22,05 in	2500 mm 98,43 in	578,80 l 152,92 gal	D	8510 mm 335,04 in	2300 mm 90,55 in	2055 mm 80,91 in	24000 kg 52910 lb

The values provided above are to be viewed as guideline values only and may alter depending on machine applications. Please request detailed quotation drawings.  
\* geometric, rounded  
\*\* maximum theoretical

For more information and details of each type, please refer to the data sheet, which is available from your Putzmeister partner.

Conversions:  
1 bar = 14.5 psi  
1 inch = 25.4 mm  
1 US Gallon = 3.785 l  
1 kg = 2.2046 lb

# The right pump for every application

	Application	Output	Pressure
<p>KOS series S-tube pump</p> 	Coarse sludges or slurries with a high proportion of solids, up to 80 mm grain size	up to 385 m <sup>3</sup> /h (1695 gpm)	up to 100 bar (1450 psi)
<p>HSP series seat valve pump</p> 	Fine grained sludges or slurries	up to 385 m <sup>3</sup> /h (1695 gpm)	up to 150 bar (2175 psi)
<p>KOV series ball valve pump</p> 	Fine grained pastes	up to 70 m <sup>3</sup> /h (310 gpm)	up to 80 bar (1160 psi)
<p>Hydraulic power pack and control cabinet</p> 	All Putzmeister pumps are driven by a hydraulic power pack	Performance:	5.5 – 1600 kW

Right to make technical amendments reserved. Illustrations partly show optional equipment. © by Putzmeister Solid Pumps GmbH 2022. All rights reserved. Printed in Germany (22/04/Sc) IT 1971-8 EN



## Putzmeister Concrete Pumps GmbH

Max-Eyth-Straße 10 · 72631 Aichtal/Germany

Phone +49 (7127) 599-0 · Fax +49 (7127) 599-988

pit@putzmeister.com · www.putzmeister.com

